

CAVIN  
*Signature*



**Large  
Formats.**

# Casks & Vats

## Large formats for delicate aromas

The Cavin cooperage is now offering large format vessels for both fermentation and aging. The expertise to produce large formats is an extension of the coopering craft, with bigger, thicker stave-wood hand-selected for this purpose.

Cavin Signature has been conceived to produce large format vessels with the same refinement and polish as Cavin barrels. We use French oak from trees that are air dried. The production process is meticulous and follows the Cavin Deep Toasting protocols, resulting in vessels that highlight fruit while enhancing mouthfeel. Our wide range of finishing options allows you to design the perfect work tool for your winery.

We work with you at each phase of the process to study the shapes, volumes and dimensions required to best meet your logistical and winemaking needs.

Large format casks and vats have many technical and enological qualities that set them apart from other fermentation and aging vessels. The aromas are fine and restrained, with a lightness and transparency that highlights fruit. Thanks to their size and shape, wooden vats promote ample surface area contact between the marc and the juice during fermentation, promoting extraction. The micro-oxygenation is unique, unlike anything that occurs in either stainless steel or cement. And the resistance to temperature changes is unmatched, creating superb fermentation kinetics.

Each Cavin Signature vessel is a handcrafted showpiece, designed specifically for you and your winery.



# Casks.

Our round and oval casks are custom made to meet your logistical and production constraints. They are entirely customizable due to our large range of accessories. We source only top-tier French oak, of the same quality as is used to produce Cavin barrels. The relatively high volume of juice and the meticulously controlled Cavin Deep Toasting process assure a subtle wood presence.

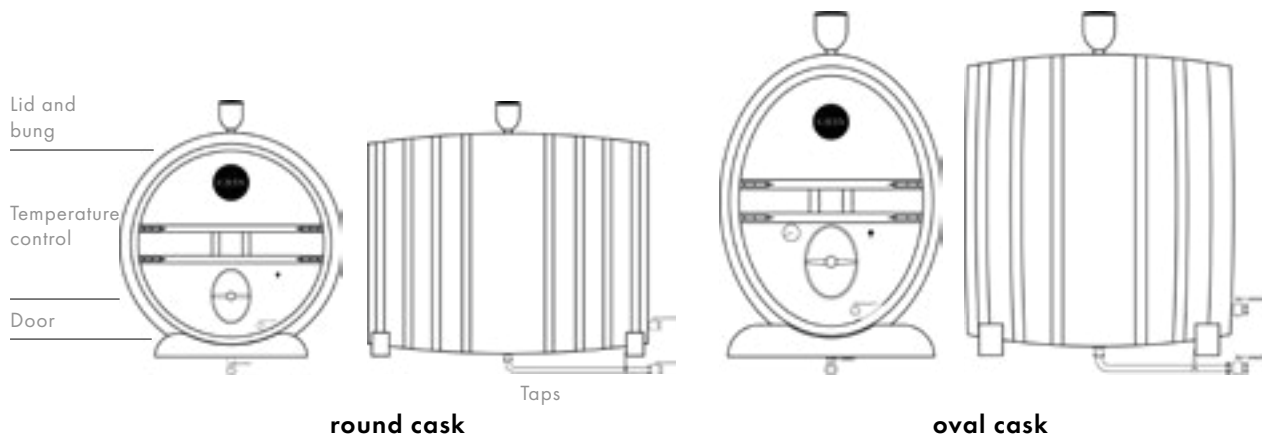

# Vats.

Our vinification and vinification-aging vats are available with a large range of customizable accessories to maximize functionality and to improve logistics in the cellar. The vats encourage tannin polymerization during fermentation, excellent temperature control and the color fixing that comes with vinification in wood.

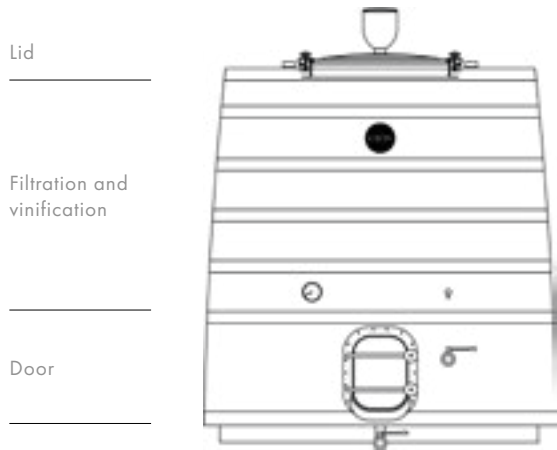

**vinification and maturation vats**

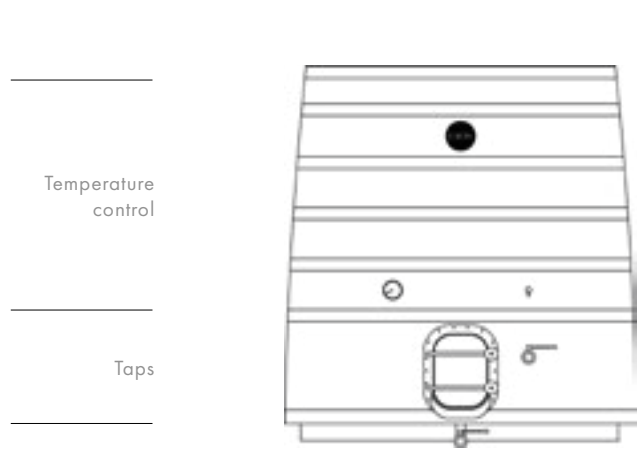

**vinification vats**



# Dimensions.

## Round Casks

Capacity (in hl)	Length (in cm)	Bilge Diameter (in cm)	Head Diameter (in cm)
10	126	127	113
15	144	143	127
20	156	156	139
25	168	167	149
30	176	177	158
35	186	185	165
40	192	193	172
45	200	200	178
50	206	207	185
55	212	212	190
60	218	219	195

## Oval Casks

Capacity (in hl)	Length (in cm)	Bilge Height (in cm)	Head Height (in cm)	Bilge Width (in cm)	Head Width (in cm)
10	138	139	125	107	93
15	156	157	141	121	102
20	172	173	155	129	111
25	184	183	164	139	120
30	196	196	175	146	125
35	204	204	183	154	133
40	212	213	191	161	139
45	222	220	197	166	143
50	228	228	204	172	148
55	234	235	211	177	153
60	240	241	216	181	161

## Vats vinification/maturation

Capacity (in hl)	Stave Length (in cm)	Low Diameter (in cm)	Top Diameter (in cm)
10	126	126	104
15	142	142	119
20	154	155	131
30	176	176	151
35	184	183	158
40	192	191	166
55	210	211	184
60	216	216	190
70	226	227	200
80	236	237	209

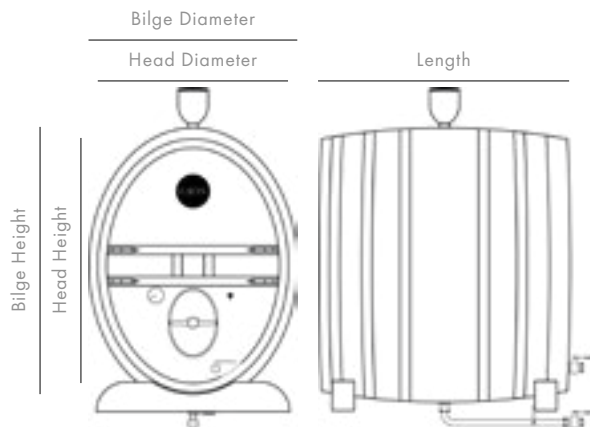

## Finishing.

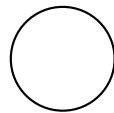

Painted or  
galvanized hoops

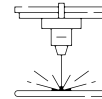

Logo marking  
on request

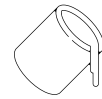

Mat or glossy  
food-grade varnish

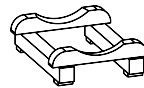

Standard  
oak stands



Custom-made  
stands



4140

4140

# Accessories.

## Common accessories

### I STAINLESS STEEL TAPS

- I1 Draining port + plug ●○
- I2 Racking valve 40/50 - Mâcon/DIN... ●○
- I3 Tube + draining valve 40/50 - Mâcon/DIN...
- I4 Taster + extension : classic, with key, Equinox ●
- I5 Arm-taste lees
- I6 Fixed level valve with tube (optional stainless-steel rule)
- I7 Gauge glass (stainless steel ruler optional)

### R TEMPERATURE CONTROL

- R1 Heating / cooling panel
- R3 Thermometer
- R4 Thermowell
- R2 Serpentine

### PB LIDS AND BUNGS

- PB6 Bung : silicone, Bellot VOG, siphoid ... ●
- PB1-1 Stainless steel lid, diameter of your choice
- PB1-2 Fully opening lid
- PB2-1 Micrometric closure system
- PB2-2 Clamp closure
- PB3 Hinges
- PB4 Stem (ask us)
- PB5 Stainless steel ring with floating lid (ask us)
- PB7 Anti-retention tube
- PB8 Stainless steel bung seat ●
- PB9 Cupola lid diam. 22 cm

### C STANDS

- C1 Oak stand with stainless steel plates ●○
- C2 Adjustable stainless steel plates
- C3 Stainless steel stand

### V VINIFICATION

- V1 Seed-screen
- V2 Lees stirring device

### D DOORS

- D1 Oval stainless steel cask door horizontal or vertical ●
- D5 Half-round stainless steel door
- D2 Stainless steel door high position or flush-mounted
- D3 Lip on rectangular door
- D4 Oval stainless-steel door

*Cavin Signature offers you a large range of accessories selected with great care by our designers to allow you to optimize your wooden containers. Feel free to speak with our experts about the ideal accessories for your vats and casks.*

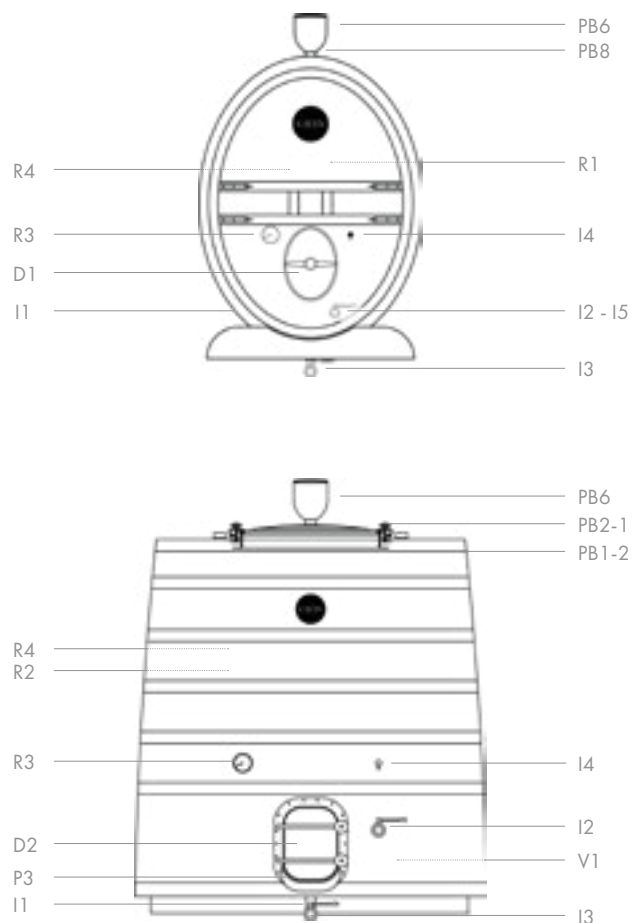

### A VARIOUS ACCESSORIES

- A1 Cover vinification vats

### S SECURITY

- S1 Ladder hook
- S2 Protection grid / guard





taster



oval stainless steel cask door



racking valve



square flange plug



Mâcon chain plug



Mâcon chain plug (butterfly)

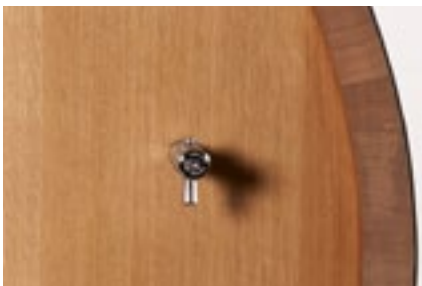

taster and extension



wood stand



adapter for aseptic bung



*All accessories made of 316L stainless steel for maximum corrosion resistance*



**Cavin Signature vats and casks are adapted to your needs, be it for fermentation or aging, and will guarantee you :**

- Elegant aromas • Unique micro-oxygenation • Better extraction
- A large range of accessories • Customized formats • Thermal inertia
- Optimized space and logistics

*specific to the vats :*

- Color fixing by vinification in wood • Temperature control
- A polymerization of tannins during fermentation





CAVIN  
*Signature*

[tonnellerie-cavin.com](http://tonnellerie-cavin.com) | Laperrière - 21450 Poiseul-la-Ville-et-Laperrière